

EWELLIX

MAKERS IN MOTION

# Profile rail guides - LLT catalogue



## WHY EWELLIX

# Profile rail guides - LLT

For smooth running performance



Linear guides provide precise guiding function to position loads in combination with linear motion driving elements.

Ewellix ball profile rail guide LLT series is available in a wide range of sizes, carriages, accessories as well as in various preload and precision classes.

The LLT series ensures a uniform load capacity in all main load directions. They are equipped with 4 rows of ball bearings. Thanks to the X arrangement with rails and carriages (block), deviations in parallelism and height can be compensated with better self-aligning capabilities, resulting in reliable and smooth operation under a wide variety of operating conditions.

LLT profile rail guides facilitate adaptation to individual application demands. In combination with their ability to operate at virtually unlimited stroke and to be designed in a multitude of different options, the LLT guides can meet the needs of a wide range of demanding applications. In addition, to the LLT series, we offer LLS - miniature profile rail guides, LLU - roller profile rail guides and LLR - (rigid) ball profile rail guides.

Ewellix manufactures LLT profile rail guides in an X-arrangement with a 45° contact angle between the rolling elements and raceways. This design promotes equal load sharing in all four main load directions to provide greater design flexibility.

Thanks to the Ewellix global network of sales units and distributors, replacement parts and services are available worldwide. Standard components are available in stock for quick delivery.

## Common applications

- Material handling equipment
- Plastic injection moulding
- Woodworking machines
- Printing and packaging machines
- Medical devices

## General features



### Better self-aligning capabilities

Four rows of balls with a 45° contact angle between the rolling elements and raceways. This X-arrangement improves the system's self-aligning capability

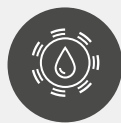

### Integrated lubrication reservoir for superior sealing performance

The integrated lubricant reservoirs constantly relubricate the circulating balls. Double lip seals on both ends, as well as side and inner seals, eliminate lubricant leakage and keep contaminants out significantly extending service life



### Modular concept for customized solutions

LLT rail guides use modular components for cost-effective solutions built based on the application's needs



### Interchangeability

Ewellix profile rail guides are in accordance with ISO 12090-1. This enables dimensional interchangeability with all ISO-compliant brands

## Ewellix broad range overview

Size	15, 20, 25, 30, 35, 45
Rail Type	Standard, blind holes and rail with metal plugs
Speed	5 m/s
Acceleration	75 m/s <sup>2</sup>
Operating temperature	Continuous: -20 to 80 °C Short-term: max 100 °C

### Rail type

LLTHR profile rail with standard holes

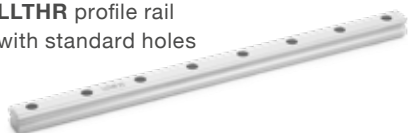

LLTHR...D4 profile rail with blind holes

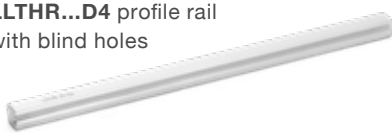

LLTHR...D6 profile rail with protective metal plugs

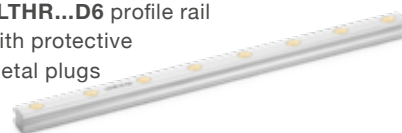

### Carriage type

LLTHC ... SA

Flanged carriage, short length, standard height



LLTHC ... A

Flanged carriage, standard length, standard height



LLTHC ... LA

Flanged carriage, extended length, standard height



LLTHC ... SU

Slim-line carriage, short length, standard height



LLTHC ... U

Slim-line carriage, standard length, standard height



LLTHC ... LU

Slim-line carriage, extended length, standard height



LLTHC ... R

Slim-line carriage, standard length, extended height



LLTHC ... LR

Slim-line carriage, extended length, extended height



**Note:** rails can be ordered cut to length and with various configurations of carriages. Rails and carriages can be ordered as individual parts or as a complete system.

## Application examples

### Plastic injection moulding

The only way to increase productivity during injection is by accurately controlling motion and achieving fast injection speeds.

- Allowed linear performance up to 5 m/s and 75 m/s<sup>2</sup>
- Highly dynamic operating cycles with greater flexibility
- The integrated lubricant reservoirs can reduce the maintenance cost by extending the maintenance intervals

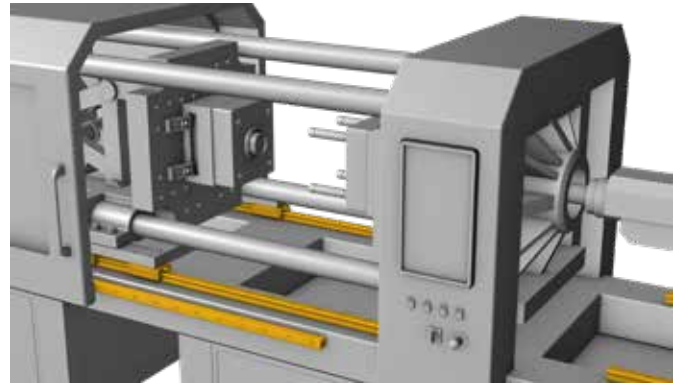

### Laboratory analysers

As more and more detection is done for prevention, the more demanding it gets for laboratory analysers. Increased speed and flexibility to measure different chemicals and other characteristics in many different biological samples with a higher quality of results is challenging and demanding.

- Improved running performance
- Linear performance up to 5 m/s and 75 m/s<sup>2</sup>
- The integrated lubricant reservoirs can reduce the maintenance cost by extending the maintenance intervals

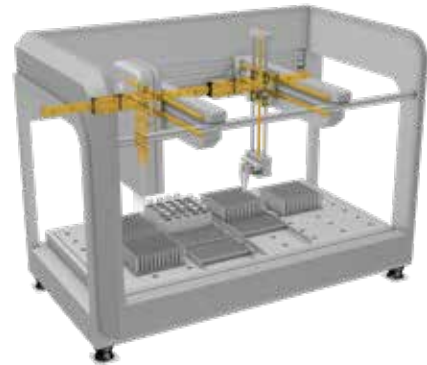

### Pick and place – Cartesian robots

Cartesian robots require superior motion control, speed, accuracy and precise repetition to meet the increased productivity of various pick-and-place applications.

- Improved running performance
- Longer service life and reduced maintenance
- Self-aligning capability carriage and dual grind rail reference sides for easy mounting

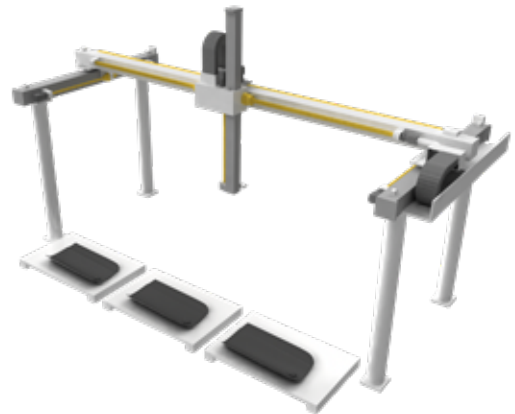

### Woodworking

Cutter tools and platforms are used for cutting or carving wood. The working environment will be full of sawdust and the rails are often exposed to the external environment.

- Improved running performance
- Good sealing against coarse and fine contaminants

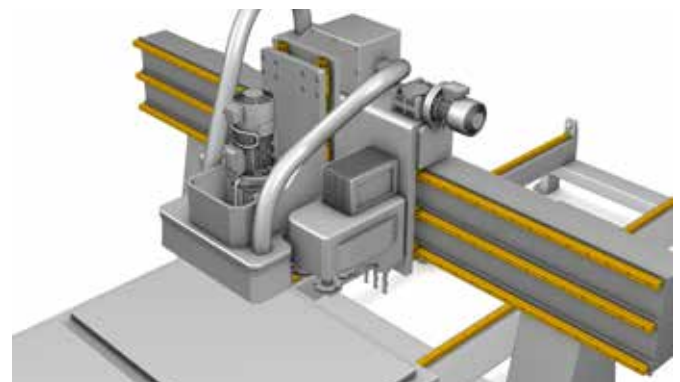

# Ewellix profile rail guides - LLT: how are they different?

## High performance, fully sealed carriage function

- Double lip seal design for the standard front, inner, and side seals
- High wear resistance material for seals
- A wide range of accessories (LLTHZ.):
  - Scraper plates
  - Additional front seals and seal kits
  - Low friction shields
  - Lube elements
  - Adapter plates
  - Grease nipples
  - Bellows
  - Plastic caps and metal plugs

## Carriage with integrated lubricant reservoirs

- The lubricant can constantly relubricate the circulating balls when the carriage is moving
- When the carriage is re-lubricated, the raceway and lubricant reservoirs will be refilled at the same time
- High performance complete seals retain the lubricant for a long time

## Easy to assemble and reduced installation time

- The X-arrangement design provide the system's self-aligning capability
- Dual grind rail reference sides allow a quicker and higher degree of flexibility during installation

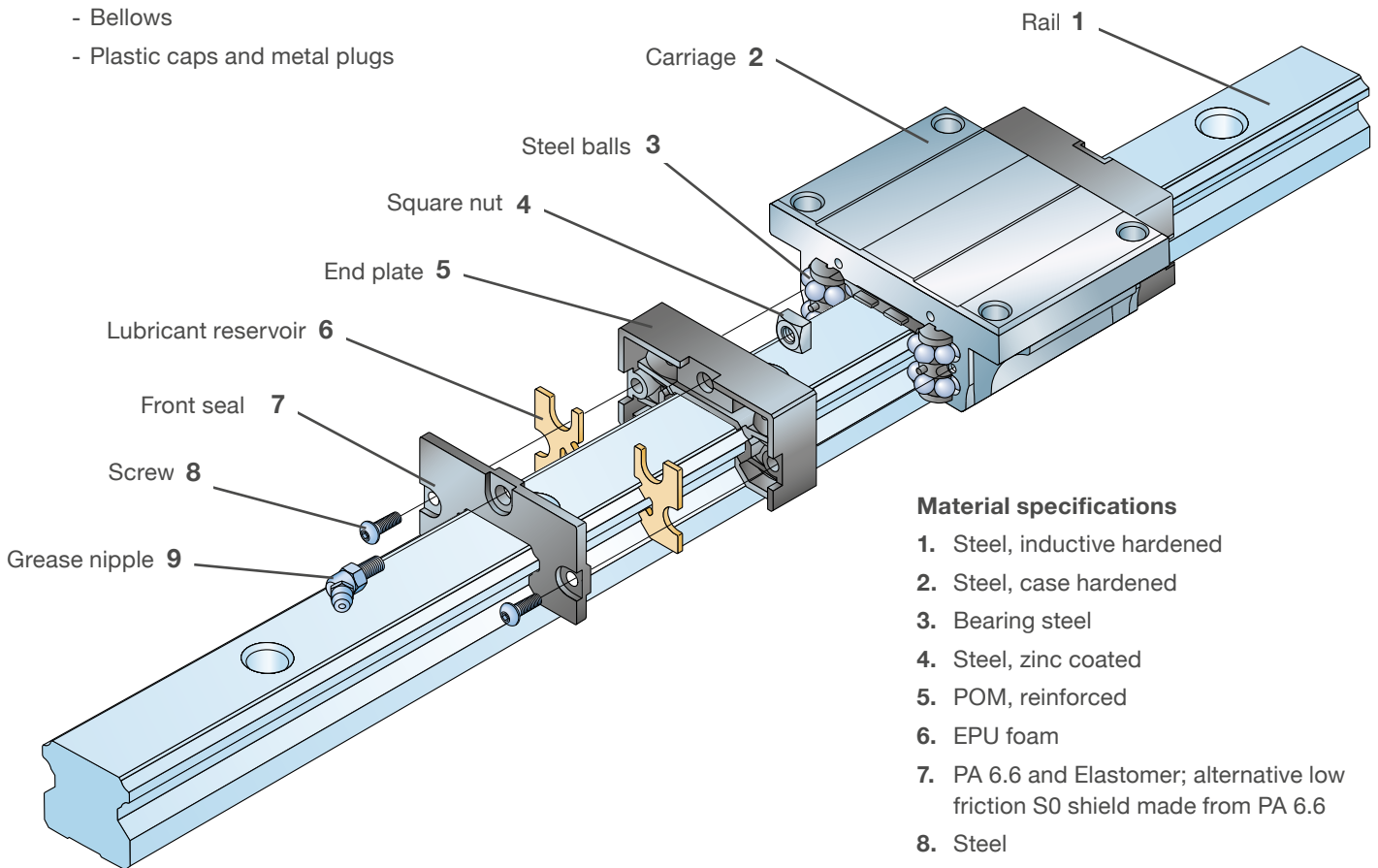

### Material specifications

1. Steel, inductive hardened
2. Steel, case hardened
3. Bearing steel
4. Steel, zinc coated
5. POM, reinforced
6. EPU foam
7. PA 6.6 and Elastomer; alternative low friction S0 shield made from PA 6.6
8. Steel
9. Steel, nickel coated



See video about  
Profile rail guide - LLT

**ewellix.com**

© Ewellix

All contents of this publication are the property of Ewellix, and may not be reproduced or given to third parties (even extracts) without permission. Although great care has been taken in the production of this catalog, Ewellix does not take any responsibility for damage or other loss resulting from omissions or typographical errors. The photo may differ slightly in appearance from the actual product. Due to continuous improvements being made in our products, the product's appearance and specifications are subject to change without notice.

PUB EL-04009-EN-April 2022

ALPHA CONTROMATIC CO., LTD.  
9 Soi On-Nuch 62, Sukhumvit 77 Rd,  
On-Nuch, Suanluang, Bangkok 10250  
T. 02 721 1801(Auto)  
LINE ID: AlphaC.sales  
sales@alphac.co.th  
www.alphac.co.th

**ewellix.com**

© Ewellix

All contents of this publication are the property of Ewellix, and may not be reproduced or given to third parties (even extracts) without permission. Although great care has been taken in the production of this catalog, Ewellix does not take any responsibility for damage or other loss resulting from omissions or typographical errors. The photo may differ slightly in appearance from the actual product. Due to continuous improvements being made in our products, the product's appearance and specifications are subject to change without notice.

**PUB NUM IL-06004/1-EN-May 2020**

SKF and SKF logo are trademarks of the SKF Group